

Kelly

Gelato & Pastry





Kelly services

With Kelly you'll store, arrange and display all your products in state-of-the-art fashion at any time of day: sweets and pastries, ice cream, cakes and pies, snacks, delicacies, minion appetizers for your happy hour and main courses for lunch or dinner.

Con Kelly conservi, organizzi e presenti a regola d'arte tutti i tuoi prodotti, in ogni momento della giornata: dolci, gelati, torte, pasticceria, snack, gastronomia, sfizioserie per l'happy hour e pietanze per il pranzo o la cena.

Cold Ventilated
Freddo ventilato

+1°C / +10°C

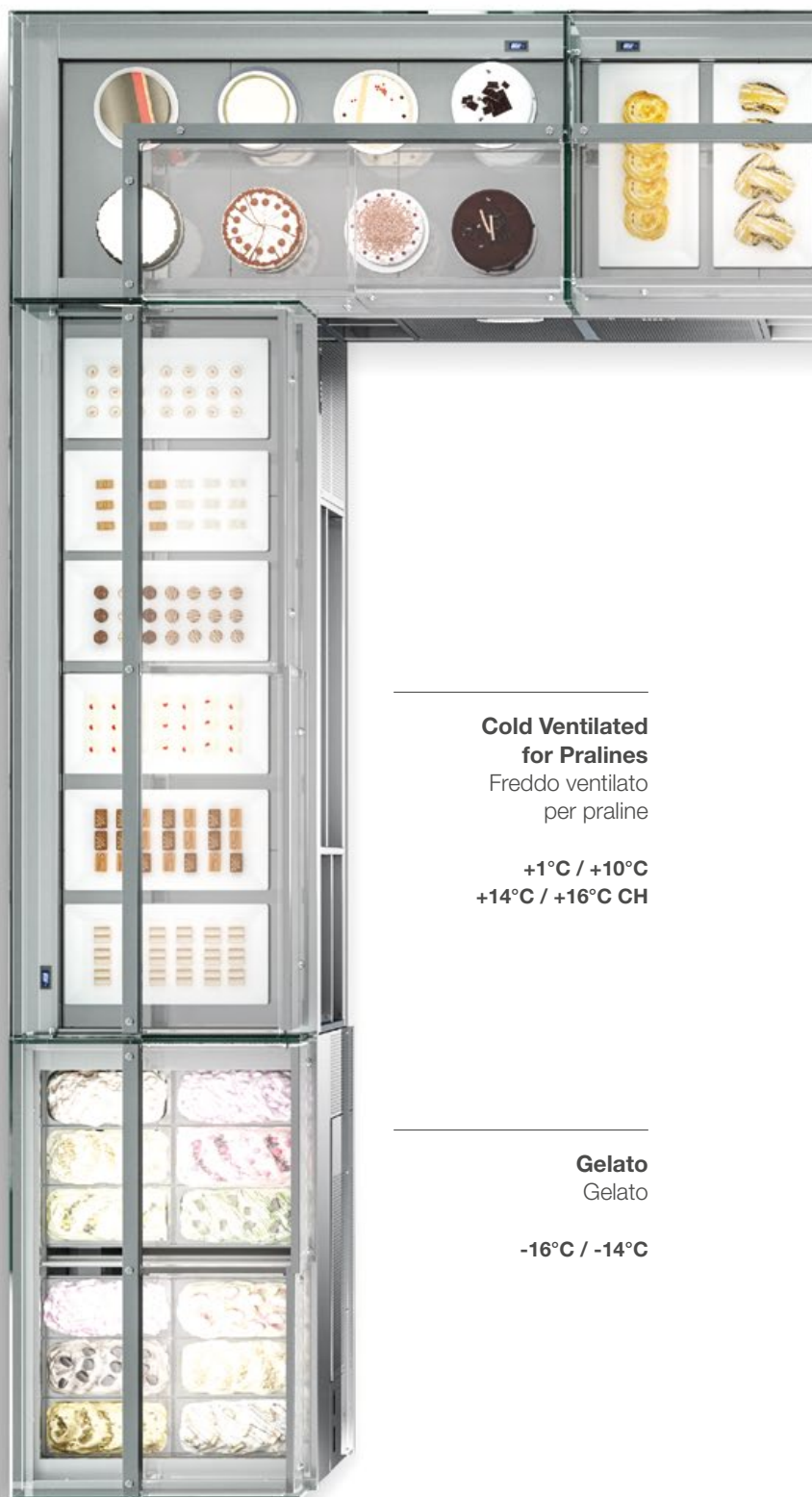

**Cold Ventilated
for Pralines**

Freddo ventilato
per praline

+1°C / +10°C
+14°C / +16°C CH

Gelato
Gelato

-16°C / -14°C

Cold Ventilated
Freddo ventilato

+1°C / +10°C

Dry hot
Vetrina Caldo Secco

+65°C



**Cold Ventilated
with hot surface**
Freddo ventilato
con piano caldo

+4°C / +8°C
+65°C

Cold pastry
Pasticceria fredda

-14°C / -12°C

Stick/Monoportion
Stecchi/Monoporzioni

-16°C / -14°C

Kelly product range



Kelly
Angolare

H 117

P 80

L 150 TDX - 150 TSX

Pastry
Pastry + Hot
Chocolate



Kelly
Lineare

H 117

P 80

L 100-125-150-175-200

Pastry

**Pastry + Hot
Chocolate**



Kelly
Gelato

H 117

P 80

L 125

Gelato

Kelly Lineare

H 117

P 80

L 100 • 125 • 150 • 175 • 200

Pastry • Chocolate • Snack • Food

	TN Chiller	TB Freezer	TB/TN Dual Temp
--	---------------	---------------	--------------------

RS-Static			
RV-Ventilated	•		
TCS-Heated	•		
CH-Chocolate	•		

Installation

Plug-in

Temperature

- +4/+8 °C (TN)
- +14/+16 °C (CH)
- +65 /+80 °C (TCS)

Refrigerant

R290

Refrigeration

Ventilated

Compressor

Hermetic

Defrost

Off cycle

Climate class

3

Front glass

Extra clear single

Side glass

Extra clear single

Rear closing system

Glass sliding doors

Lighting

Led 3000 K

Base

Height adjustable feet

Color

White RAL 9003

Installazione

Plug-in

Temperatura

- +4/+8 °C (TN)
- +14/+16 °C (CH)
- +65 /+80 °C (TCS)

Refrigerante

R290

Refrigerazione

Ventilata

Compressore

Ermetico

Sbrinamento

Fermata compressore

Classe Climatica

3

Vetro frontale

Singolo extrachiaro

Vetri laterali

Singolo extrachiaro

Chiusura posteriore

Scorrevoli in vetro

Illuminazione

Led 3000 K

Basamento

Piedini regolabili in altezza

Colore

Bianco RAL 9003



R290



KELLY LINEARE		Cabinet type Tipo di banco	Total display area Superficie espositiva totale m ²	Temperature class Classe di temperatura	Recommended temperature Temperatura consigliata °C	Energy class Classe energetica	Energy efficiency index Indice di efficienza energetica EEI	Annual energy consumption Consumo annuo AEC kWh/A	Light source type and class Tipo e classe illuminazione
Height Altezza	Length Lunghezza								
H117	100	IHC1	0,53	M2	+4°C	F	79,95	1.781	
	125	IHC1	0,67	M2	+4°C	G	92,66	2.243	
	150	IHC1	0,80	M2	+4°C	G	97,03	2.537	
	175	IHC1	0,94	M2	+4°C	G	97,03	2.725	
	200	IHC1	1,08	M2	+4°C	G	99,41	2.984	

Configuration: air-cooled plug-in unit R290, LED canopy lighting, rear closure with sliding doors, without evaporation tray

Configurazione: unità condensatrice plug-in R290, illuminazione LED superiore, chiusura posteriore con scorrevoli posteriori, senza vaschetta asciugacondensa



100			125		
RV TN	RV CH	TCS	RV TN	RV CH	TCS

External dimensions (LxDxH) Dimensioni esterne (LxPxH)	H117	1000x819x1170 mm			1250x819x1170 mm	
Capacity (gross/net) Capacità (lorda/netta)	H117	-			-	
Net weight Peso netto	H117	-	-	-	-	-
Refrigeration Refrigerazione		Ventilated Ventilata		-	Ventilated Ventilata	
Refrigerant Refrigerante		R290		-	R290	
Climate class Classe climatica		3				
Operating conditions Condizioni ambientali		25 °C / 60 %RH				
Product temperature Temperatura prodotto		+4/+8 °C	+14/+16 °C	+65/+80 °C	+4/+8 °C	+14/+16 °C
Compressor (q.ty - type) Compressore (q.tà - tipologia)		1 - Hermetic 1 - Ermetico		-	1 - Hermetic 1 - Ermetico	
Defrost Sbrinamento		Off Cycle Fermata compressore		-	Off Cycle Fermata compressore	
Power supply Alimentazione		230 V / 1 Ph / 50 Hz				
Electrical input (nominal) Assorbimento elettrico (regime)		411 W / 2,1 A	595 W / 2,7 A	740W / 3,6 A	418 W / 3 A	502 W / 2,7 A
Electrical input (defrost) Assorbimento elettrico (sbrinamento)		242 W / 1,3 A		-	229 W / 1,3 A	

Technical sheet about models whit condensing unit included with air cooled
Dati tecnici riferiti a modelli con unità a bordo con condensazione ad aria

Setup

Allestimento

Bottom shelf (LxD) Ripiano di fondo (LxP)	1000 x 602 mm	1250 x 602 mm
---	---------------	---------------

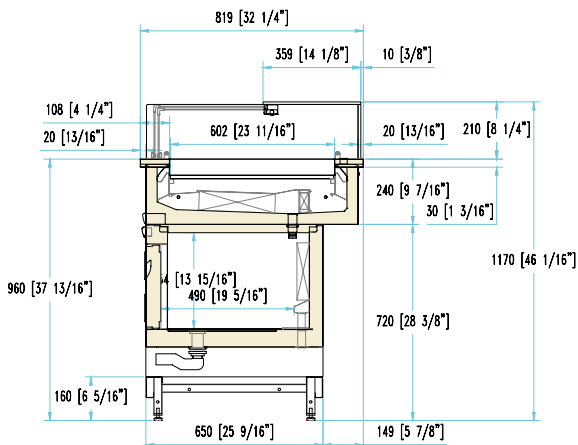

150			175			200		
RV TN	RV CH	TCS	RV TN	RV CH	TCS	RV TN	RV CH	TCS
1500x819x1170 mm			1750x819x1170 mm			2000x819x1170 mm		
-			-			-		
-	-	-	-	-	-	-	-	-
Ventilated Ventilata	-	-	Ventilated Ventilata	-	-	Ventilated Ventilata	-	-
R290	-	-	R290	-	-	R290	-	-
3								
25 °C / 60 %RH								
+4/+8 °C	+14/+16 °C	+65/+80 °C	+4/+8 °C	+14/+16 °C	+65/+80 °C	+4/+8 °C	+14/+16 °C	+65/+80 °C
1 - Hermetic 1 - Ermetico		-	1 - Hermetic 1 - Ermetico		-	1 - Hermetic 1 - Ermetico		-
Off Cycle Fermata compressore		-	Off Cycle Fermata compressore		-	Off Cycle Fermata compressore		-
230 V / 1 Ph / 50 Hz								
498 W / 3 A	597 W / 3,2 A	1120 W / 5,4 A	504 W / 3,6 A	603 W / 3,3 A	1320 W / 6,4 A	567 W / 4,1 A	788 W / 4,3 A	1500 W / 7,2 A
307 W / 1,6 A		-	313 W / 1,7 A		-	450 W / 2,4 A		-

1500 x 602 mm	1750 x 602 mm	2000 x 602 mm
---------------	---------------	---------------



Available colours - Colori disponibili

Front panel (1) - Side panels (2)
Pannello frontale (1) - Fianchi laterali (2)

-  RAL 9003
-  RAL on request
- Standard / Di serie

Kelly Angolare

H 117

P 80

L 150 TDX • 150 TSX

Pastry • Chocolate • Snack • Food

	TN Chiller	TB Freezer	TB/TN Dual Temp
RS-Static			
RV-Ventilated	•		
TCS-Heated	•		
CH-Chocolate	•		

Installation

Plug-in

Temperature

- +4/+8 °C (TN)
- +14/+16 °C (CH)
- +65 /+80 °C (TCS)

Refrigerant

R290

Refrigeration

Ventilated

Compressor

Hermetic

Defrost

Off cycle

Climate class

3

Front glass

Extra clear single

Side glass

Extra clear single

Rear closing system

Glass sliding doors

Lighting

Led 3000 K

Base

Height adjustable feet

Color

White RAL 9003

Installazione

Plug-in

Temperatura

- +4/+8 °C (TN)
- +14/+16 °C (CH)
- +65 /+80 °C (TCS)

Refrigerante

R290

Refrigerazione

Ventilata

Compressore

Ermetico

Sbrinamento

Fermata compressore

Classe Climatica

3

Vetro frontale

Singolo extrachiaro

Vetri laterali

Singolo extrachiaro

Chiusura posteriore

Scorrevoli in vetro

Illuminazione

Led 3000 K

Basamento

Piedini regolabili in altezza

Colore

Bianco RAL 9003



R290

Kelly Angolare

		TDX			TSX		
		RV TN	RV CH	RV TN / TCS	RV TN	RV CH	RV TN / TCS
External dimensions (LxDxH) Dimensioni esterne (LxPxH)	H117	1500x819x1170 mm			1500x819x1170 mm		
Capacity (gross/net) Capacità (lorda/netta)	H117	-			-		
Net weight Peso netto	H117	210 kg			215 kg		
Refrigeration Refrigerazione		Ventilated Ventilata		-	Ventilated Ventilata		-
Refrigerant Refrigerante		R290			R290		
Climate class Classe climatica		3					
Operating conditions Condizioni ambientali		25 °C / 60 %RH					
Product temperature Temperatura prodotto		+4/+8 °C	+14/+16 °C	+65/+80 °C	+4/+8 °C	+14/+16 °C	+65/+80 °C
Compressor (q.ty - type) Compressore (q.tà - tipologia)		1 - Hermetic 1 - Ermetico		-	1 - Hermetic 1 - Ermetico		-
Defrost Sbrinamento		Off Cycle Fermata compressore		-	Off Cycle Fermata compressore		-
Power supply Alimentazione		230 V / 1 Ph / 50 Hz					
Electrical input (nominal) Assorbimento elettrico (regime)		418 W / 3 A	502 W / 2,7 A	930 W / 04,5 A	418 W / 3 A	502 W / 2,7 A	930 W / 04,5 A
Electrical input (defrost) Assorbimento elettrico (sbrinamento)		229 W / 1,3 A		-	229 W / 1,3 A		-
Technical sheet about models whit condensing unit included with air cooled Dati tecnici riferiti a modelli con unità a bordo con condensazione ad aria							
Setup Allestimento							
Bottom shelf (LxD) Ripiano di fondo (LxP)		1400 x 602 mm			1400 x 602 mm		

Kelly Gelato

H 117
P 80
L 125

Gelato

	TN Chiller	TB Freezer	TB/TN Dual Temp
RS-Static			
RV-Ventilated		•	
TCS-Heated			
CH-Chocolate			

Installation

Plug-in

Dual Zone

-20/+2 °C
(max. 10 °C difference
between right and left side)

Refrigerant

R290

Refrigeration

Side ventilation
(Patented)

Defrost

Hot Gas

Climate class

4

Upper glass

Single heated

Front glass

Single heated

Side glass

Heated laminated

Rear closing

Plexiglass sliding lids

Service top

Stainless steel

Lighting

Led 3000 K

Night mode

Night closing system.
Allows the gelato
to be perfectly preserved
by interrupting
the defrost cycle.

Equipment handling

Height-adjustable feet

Installazione

Plug-in

Dual Zone

-20/+2 °C
(max 10 °C di differenza
tra la parte destra e la parte
sinistra della vasca)

Refrigerante

R290

Refrigerazione

Ventilazione laterale
(Patented)

Sbrinamento

Gas caldo

Classe climatica

4

Vetro superiore

Singolo riscaldato

Vetro frontale

Singolo riscaldato

Vetri laterali

Stratificati riscaldati

Chiusura posteriore

Scorrevoli in plexiglas

Piano di servizio

Acciaio inox

Illuminazione

Led 3000 K

Night mode

Sistema di chiusura notturna.
Permette di conservare
il gelato perfettamente
grazie all'interruzione
del ciclo di sbrinamento.

Movimentazione

Piedini regolabili in altezza



R290

KELLY GELATO	Model type Tipo di banco	Total display area Superficie espositiva totale m ²	Temperature class Classe di temperatura	Recommended temperature Temperatura consigliata °C	Energy class Classe energetica	Energy efficiency index Indice di efficienza energetica EEI	Annual energy consumption Consumo annuo AEC kWh/A	Light source type and class Tipo e classe illuminazione	
Height Altezza	Length Lunghezza								
H117	125	IGF1	0,71	G2	-15	C	33,00	5.621	-

Configuration: air cooled plug in unit R290, plexiglass sliding doors closure, led lighting.

Configurazione: motore a bordo ad aria R290, chiusura porte scorrevoli in plexiglass, illuminazione led.

Kelly Gelato





125

External dimensions (LxDxH) Dimensioni esterne (LxPxH)	1250 x 819 x 1170 mm
Capacity (gross/net) Capacità (lorda/netta)	180 / 130 lt
Net weight Peso netto	150 kg
Refrigeration Refrigerazione	Ventilated - Ventilata
Refrigerant Refrigerante	R290 (Plug-in)
Climate class Classe climatica	4
Operating conditions Condizioni ambientali	30 °C / 55 %RH
Temperature range Temperatura di regolazione	-20/+2 °C
Product temperature Temperatura prodotto	-16/-14 °C
Compressor (type) Compressore (tipologia)	2 Hermetic - 2 Ermetici
Defrost Sbrinamento	Hot gas - Gas caldo
Power supply Alimentazione	230 V / 1 Ph / 50 Hz
Electrical input (nominal) Assorbimento elettrico (regime)	1350 W / 7,4 A
Electrical input (defrost) Assorbimento elettrico (sbrinamento)	1240 W / 6,6 A

Technical sheet about models whit condensing unit included with air cooled
Dati tecnici riferiti a modelli con unità a bordo con condensazione ad aria.

Setup

Allestimento

5 Lt 360x165x120hx150h		12 (6+6)
5 Lt 360x250x80hx120hx150h		8 (4+4)
Tray Vassoio		4 (2+2)
Ice cream stick container Vaschetta stecchi		8 (4+4)
Single portions container Vaschetta monoporzioni		8 (4+4)

